

26 SERIES

- HALOGEN CYCLE SINGLE CONTACT DOUBLE ENDED LAMPHOLDERS
- 4" WIRE LEAD OR 1/4" TAB TERMINAL • HEAT RESISTANT CERAMIC HOUSING
- MAXIMUM RATING: 2000 WATTS, 600 VOLTS
- TWO LAMPHOLDERS REQUIRED PER LAMP • NON-GROUNDED LAMPHOLDERS
- UL AND CSA RECOGNIZED • UL FILE E20356 • CSA FILE LR 15284-9

Overview

The 26 Series lampholders are constructed with a high heat resistant ceramic housing and one 4" wire lead or 1/4" tab terminal. Lampholders are non-grounded. Lampholders are designed for use with double ended single contact halogen lamps. Note: Two lampholders are required for use with each lamp.

Specifications

Housing: ceramic.

Contact: silver plated copper.

Wire leads:

4" lead: #18 AWG, black, tinned copper, silicone rubber, lacquered glass braid, UL Label SF-2 and CSA SEW-2, UL/CSA rated 600 volts, 200° C, stripped 1/2". Non-grounded units are supplied individually with one 4" wire lead. Custom wire lengths, stripping, termination and wire types are also available.

Terminals:

1/4" tab: zinc plated steel, 0.250" length x 0.032" width. Non-grounded units are supplied individually with one 1/4" tab terminal.

Maximum rating: 2000 Watts, 600 Volts.

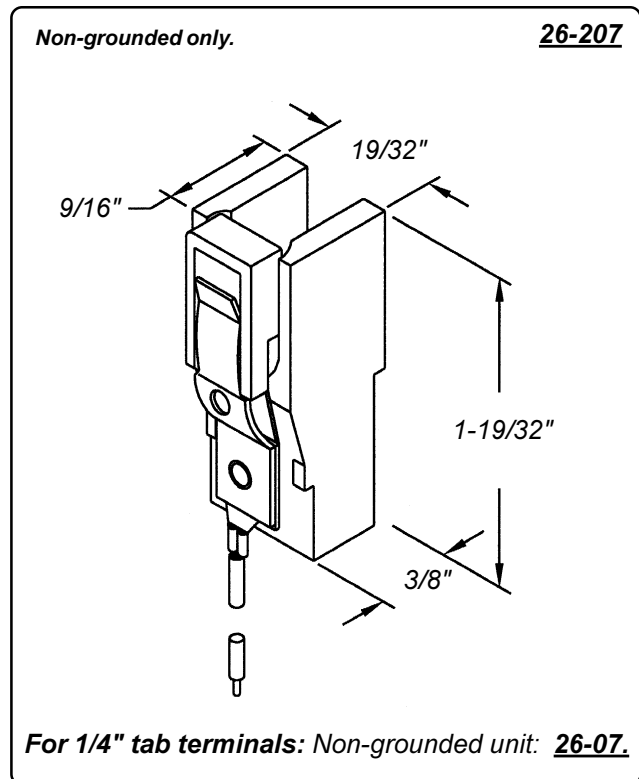

Can't find it here? We have many more standard and custom solutions.

The items in this catalog are only a small representative sample of the complete LC&D-Leecraft product line. We manufacture many additional products which are not shown in this catalog due to space constraints.

Custom products can also be designed uniquely for you by our Technical Support Professionals. Starting from your ideas and specifications, we work with your personnel to develop timely and cost effective solutions for your miniature lighting needs.

LC&D Technical Support Services are provided without charge and may include designs, prototypes and pre-production samples.

For further information phone Customer Service at 954-425-0123 or complete the "Fast FAX Technical Support Inquiry" form located in the Appendix, page A-1.